

Efficient Technique to Improve Energy Exhausting in Intra-clustering Communication for WSN

Aqeel K. Kadhim

Al Neelain University, AL Khartoum-Sudan

kadhimaqeel@gmail.com

Abstract

Member nodes in a wireless sensor networks are split into many virtual sets called cluster. Each cluster will be formed of a cluster head and cluster members. Clustering techniques are an energy efficient process that prolong the network lifetime. Intra-cluster communication is the energy efficient major factor in clustering protocols. The dissipated energy in intra-cluster will primary depends on the communication between member nodes and its cluster head. Sensor node which equipped with camera for intruder detection in a monitoring area, need to transfer the captured image to cluster head directly. The improvement of powerful compression method is much needed to minimize the requirement of communication bandwidth; minimize the redundancy of data packets and to overcome the energy limitation of wireless sensor. The proposed improved technique has extra benefit to enhance the saving energy and to eliminate the consumption energy to prolong the entire network lifetime, by present a significant data reduction for the tested images.

The experimental results present that the proposed hybrid image compression scheme which uses distinct image coding scheme based on wavelet transform that combined effective types of compression algorithms for further compression. EZW and SPIHT algorithms are types of significant compression techniques that obtainable for lossy image compression algorithms. This hybrid technique will improved the efficiency of compression ratio between 8.1to 31.4%, and will present a promising preservation energy technique in intra-clustering communication by the ratio between 17.8 to 36.7% (depends on the specifications of the tested image), which prolong the entire network lifetime. From the results obtained, it became clear to us that the image with high color variation has high compression ratio, lead to get high gain in energy for processing and transmission the compressed data.

Key words: Dual compression, image compression, intra-clustering, energy consumption.

الخلاصة

المتحسسات في شبكات المتحسسات اللاسلكية تقسم نظريا الى عدة مجاميع تسمى المجاميع العقدية. كل مجموعة مكونة من اعضاء و المتحسس القائد. ان تقنية تجميع العقد تعتبر من الاجراءات الكفوءة لاطالة عمر الشبكة. ومن طرق المحافظة على طاقة الشبكة طريقة تسمى اتصالات العقد الداخلية. ان الطاقة الرئيسية والتي يتم صرفها في مثل هذا النوع من الاتصالات هي بين عناصر العقدة. ان المتحسسات التي تولف هذه العقد مزودة بكاميرات لغرض التقاط الصور لاي متطفل الى داخل المنطقة التي يتم مراقبتها. ان الصور التي يتم التقاطها ترسل الى المتحسس القائد للمجموعة والذي يتم اختياره لكونه يتميز باحتوائه على اعلى طاقة من بين المجموعة. في شبكة المتحسسات الصور الرقمية غير المضغوطة تحتاج الى سعة تخزين كبيرة ، ونتيجة لذلك تحتاج الى قناة نقل ذات سعة كبير لا يصال البيانات الى الجهة المطلوبة عبر الشبكة، ان تقنيات ضغط الصور ليس فقط تقلل حجم البيانات المخزونة فحسب ، بل تحافظ أيضا على جودة الصورة المخرجة. في البحث المقترح نستعرض تقنية لتحسين عملية صرف الطاقة والتي تنعكس ايجابيا لاطالة عمر الشبكة.

من خلال النتائج العملية تبين لنا ان استخدام طريقة هجينة لضغط الصور والتي تجمع خوارزميتين واللتان تعتبران من التقنيات المهمة لضغط الصور قبل ارسالها، والتي (SPIHT و EZW) انتجت تقنية واعدة لضغط الصور الثابتة من خلال تقليل عدد البتات المطلوبة لتمثيل الصورة إلى من النتائج التجريبية تبين الدرجة المسموح بها دون تأثير كبير على جودة الصورة المعاد بناؤها. ازدياد في كفاءة ضغط الصورة بحدود ٨ إلى ٣١٪ من حجم الصورة الاصيلي، والتي انعكست ايجابيا على مقدار صرف الطاقة لنقل الصور وذلك بتوفير بحدود ١٧ الى ٣٦٪ من الطاقة الكلية المتاحة.

1. Introduction

The cluster head in wireless sensor network, will receive sensing data that collected from monitoring area by active sensor node. The process of transferring the sensed data from active node in the monitoring area within cluster, to the CH is called intra-cluster. The intra-clustering communication is the prime factor that effects on the efficiency of energy in clustering protocols [1][2].

The sensor nodes which deployed over a geographical area will communicate wirelessly through wireless links [3]. The main task of the associated sensors is to monitoring physical phenomena like seismic events, vibrations, temperature, humidity, and more another number of

applications like border surveillance or any other military applications and health related applications [4].

Since nodes in wireless sensor networks are generally small size and equipped with limited energy, because of sensor nodes commonly operate in harsh environment with small capacity of energy source. The process of changing or replacing the sensor battery is difficult if not impossible; nodes may be deployed in unfriendly or unpractical environment. [4][3].

Energy exhaustion is a vital issue in prolong the network lifetime, the draining of minimum quantity of energy is to remain the network from failure. In wireless sensor network data transferring is the most energy constraint task. The lifetime of whole component in network should be long enough to achieve the application requirements. In the past two decades there are numerous papers which offered different ways to extend the wireless network life time. Data compression by active nodes before transmit to CH in intra-clustering, is one of important way to reduce the transmitting data.

Figure 1, shows a monitoring area equipped with homogenous nodes that provide with camera to capture image for any event driven. Data compression by active node before sends to its associated cluster head will reduce the energy dissipation for transmitting data in intra-clustering communication. Energy conservation is a critical matter in wireless sensor networks system design.

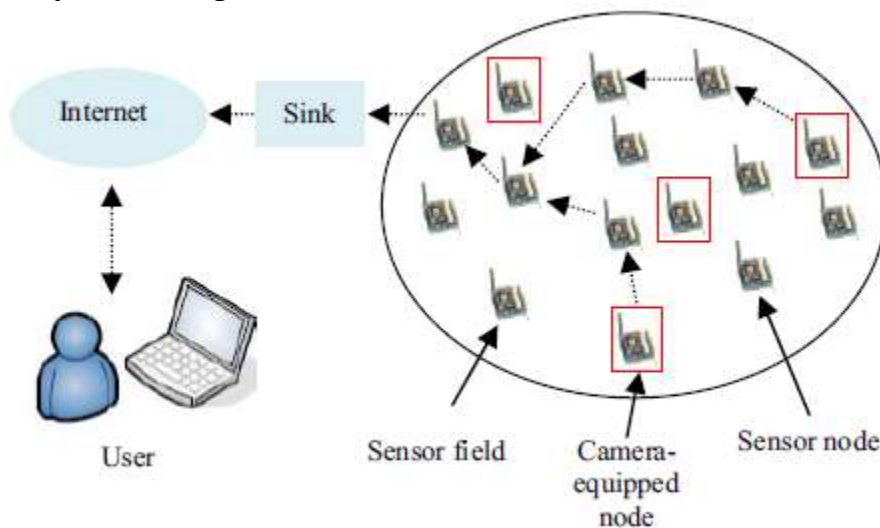

Figure 1: Present monitoring area [20]

In intra-clustering the communication processes is done through three steps:

- Active sensor node will transmit the collected data to its cluster head (CH).

- CH aggregate and process the collect data send by its associated sensor node members.
- CH then transmits data to the sink node by one hop or relay sensed data to other CH in multi-hop routing.

One of appropriate methods that eliminate the use of energy and improve the network lifetime in clustering communication is data compression before transmission [3]. Data gathering techniques in clustering algorithms decrease the collected data by cluster head to the degree that eliminate the utilized consumed energy, cluster head also responsible to send the collected data to the sink or base station directly in one-hop routing, or relay sensed data to next hop cluster head in hierarchal routing protocol [6] [7].

In this paper, a hopeful dual combined compression method for sensing data is present which has additional benefit to improve power saving and to eliminate the consumption energy in the entire network, by submit a significant data reduction method for the tested capturing images. As a result, this technique will reduce the intra-cluster communication which improves the energy efficiency of the proposed cluster.

The experimental results present that the dual combined compression method has an important enhancement on the entire network lifetime when utilizing in intra-clustering communication.

The major components of ordinary sensor node architecture will be presented in Figure 2. The sensing unit for data gathering from the physical environment, a microcontroller for processing the data locally, a transceiver which is a wireless communication unit that transmit and receive signals to and from other nodes, power source (a battery) for supply energy needed by the device to perform the required task, analog to digital convertor ADC and memory unit for store data locally. The sensing unit holds the information from the physical environment of network area; the sensor will activate the camera unit to capture the image of event driven and then relay the data to ADC unit to obtain digitized information. The processor unit will get the data for processing and then either transfer it to transceiver unit which contains both transmitter as well as receiver, or will transfer the process data to memory for storing. All physical components of sensor architecture based on power supply for working, this power must provide from batteries [5].

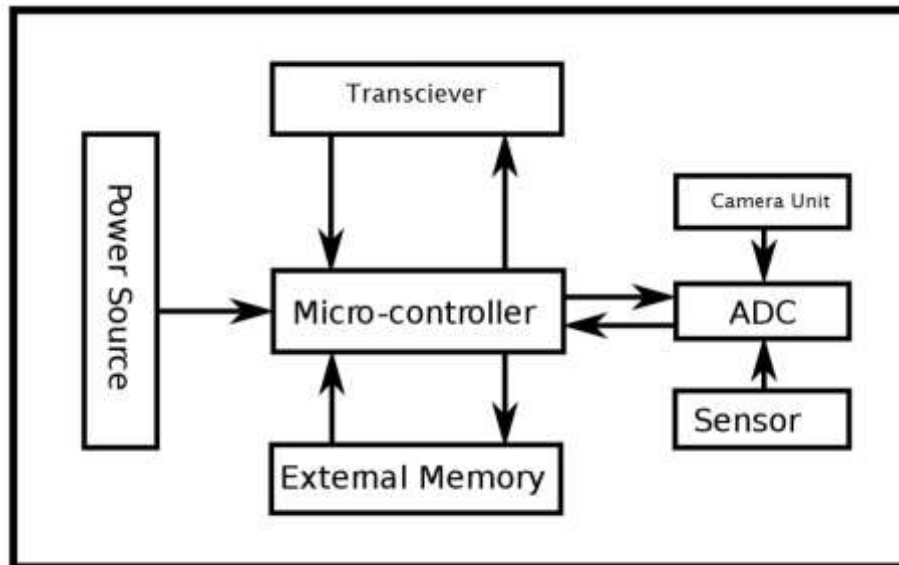

Figure 2: Architecture of sensing node [5]

The rest of the paper are arrange as follows. Section II will present the related work. Section III will describe the Improvement of Intra-Clustering Communication. Section IV Proposed Model. Experimental results are shown in Section V. Section VI concludes the paper.

2. Related Work

The compression of data is one of the significant field of studies the resource constraint for sensor networks. Many various research studies are seeking for powerful way to decrease sensing data by utilizing compression techniques, in order to reduce the consumed energy due to computation, processing and transmitting of sensing data of each node, which at the end will extend the entire network lifetime and also reduce the demand bandwidth for transmitting and receiving data [8].

A powerful solution to the problems that related for image data transmission in wireless sensor applications is presented in [9]. Performance estimation present that the proposed technique will reduced the communication process consumed energy by reducing the bits transmitted and therefore extends the entire network lifetime. A novel algorithm that utilize for lossless compression to respectably improve the performance in data compression for several applications and data collections in WSNs is submit in [10], also present article that widespread predictive coding framework for merged two technique of data

compression (lossless and lossy). Also in [11] proposed new schema which called hybrid 2-D DWT-Zonal DCT, which give better enhancement on the compression ratio and PSNR. Beside that offered in his paper, that the sharing of data compression between sensors nodes will reduced network consumed energy. [12] Present energy efficient technique for image compression that depends on Discrete Wavelet Transform (DWT) by utilizing lifting scheme. The experimental test shows that the proposed method will present a significant reduction in consumed energy needed, with little distortion in image quality. Compression methods for providing enhancement in using limited constraint of WSNs are presented in [13]. In this comparative study has been analyzed the characteristics of all proposed compression techniques and found that some of them will providing better compression rates and will save energy consumption. In [14] suggests in his work that there are three elements of power consumption, (i) computational cost (ii) communication cost (intra-clustering) between sensor nodes and cluster head (iii) communication cost (inter-clustering) between sensor node and base station. The computation cost of wavelet coefficient with lifting scheme is very low as matching with other components of energy consumption. Therefore, this system will achieve a perfect power saving.

An image compression and transmission method is proposed in [15], which based on non-negative matrix factorization (NMF). Simulation results present that the proposed method has a higher recovered images quality and lower whole node power consumption as compared with other compression schemes like JPEG2000 and singular value decomposition (SVD). The gained advantages are the reduction in energy consumption and prolong the entire network lifetime, which has great important for practical implementation of wireless sensor networks.

3. Improvement of Intra-Clustering Communication

Clustering is approach that divide wireless sensor networks into many virtual groups; each group is contain a number of sensor nodes. The cluster is consists of a leader called a cluster head and members of sensor nodes. Figure 3, present the cluster structure [16].

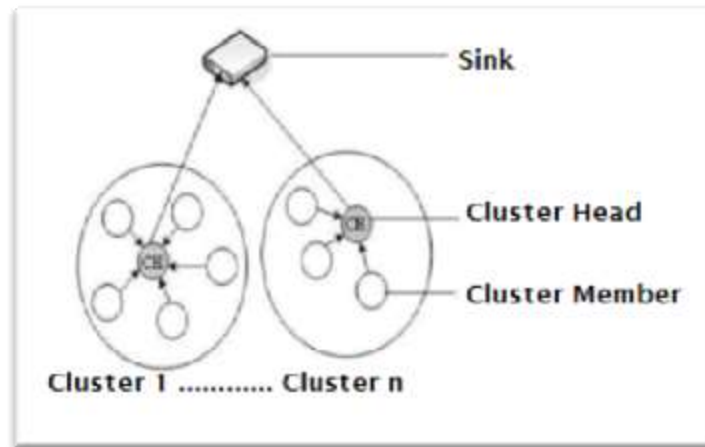

Figure 3: Cluster structure [16]

Clustering scheme is used to minimize the consumed energy in wireless sensor networks. The process of clustering will prolong network lifetime by balancing sensor energy level. The cluster head (CH) is a node with distinctive characteristics, the responsibility of CH is (i) communications with all nodes in the cluster and (ii) collect data that send from sensor members and forwarding data to other CH or to base station or sink node [17][4].

The selection of CH is an important issue in wireless sensor network, the improper selection of CH will dramatically effects on the consumed energy in clustering scheme. For this reason the selection of CH is vital issue to minimize intra-cluster communication [1]. CHs election is based primary on two parameters: firstly is the residual energy of node. Therefore, high residual energy node has high probability of selection as a CH. Secondly is communication cost of intra-cluster, which is a function of the following metrics: (i) cluster features, like cluster size; (ii) each node want to connect to its CH, must utilize minimum power level or must use the same power level for all intra-cluster communication [4].

For simplify, the intra-clustering communication between active nodes and CHs is done directly or through the hierarchical scheme [2]. On the other hand, inter-cluster communications is established when the connection between CH and base station or between two CHs, which is one of CHs responsibility [18]. Moreover CH will manage the communication process through: (i) collect the transmitting data from active nodes, sends the aggregate data to the CH in next hop in multi-hop routing. (ii) A CH will forward the receive data from another CH to next hop [19] [2].

The energy dissipation of CHs in multi-hop routing algorithms is divided into two types (i) intra-cluster energy dissipation and (ii) inter-cluster

energy dissipation. But in one-hop communication clustering algorithms only inter-cluster energy dissipation between CHs and sink [2].

One of the most important jobs in our consideration is the computation of consumed energy in intra-clustering communication in order to extend the network lifetime as long as possible.

Briefly, the main task of this paper is how to prolong entire network lifetime through reducing the intra-clustering communication energy, via compression the transmitting data from active node to its cluster head. Figure 4 shows the structure of intra-clustering data gathering scheme.

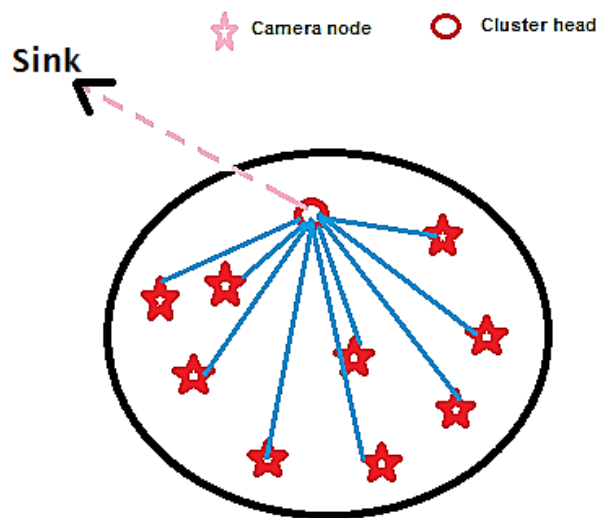

Figure 4: The intra-clustering data gathering scheme

4. Proposed Model

The proposed model architecture consists of a sink node and a number of homogenous nodes. Each cluster contains sensor member nodes and an elected cluster head. The cluster head will collect the sensing data from member nodes and forward the sensed data to the sink directly or by multi-hop. Figure 5 presents the flow chart of the proposed model.

In our proposed system the following presumption must be considered:

- 1- All nodes in WSN are homogenous.
- 2- All nodes position is fixed when deployed in observation area.
- 3- Sensor nodes are randomly distributed.

- 4- Each node has an ID number.
- 5- Single sink node which positioned out of the scope field.
- 6- All sensors nodes in the field must have data to be transmitted.
- 7- Each individual cluster consists of a member of nodes.
- 8- Node with high energy and closet distance to base station is select as cluster head.
- 9- The initialized energy is same for all sensors.
- 10- Intra-clustering links are symmetric.
- 11- Sensor node equipped with camera that sense the monitoring area.
- 12- Each send packet has same size which equal to 4000 bits.
- 13- The node is considered to die only when their energy is exhausted.

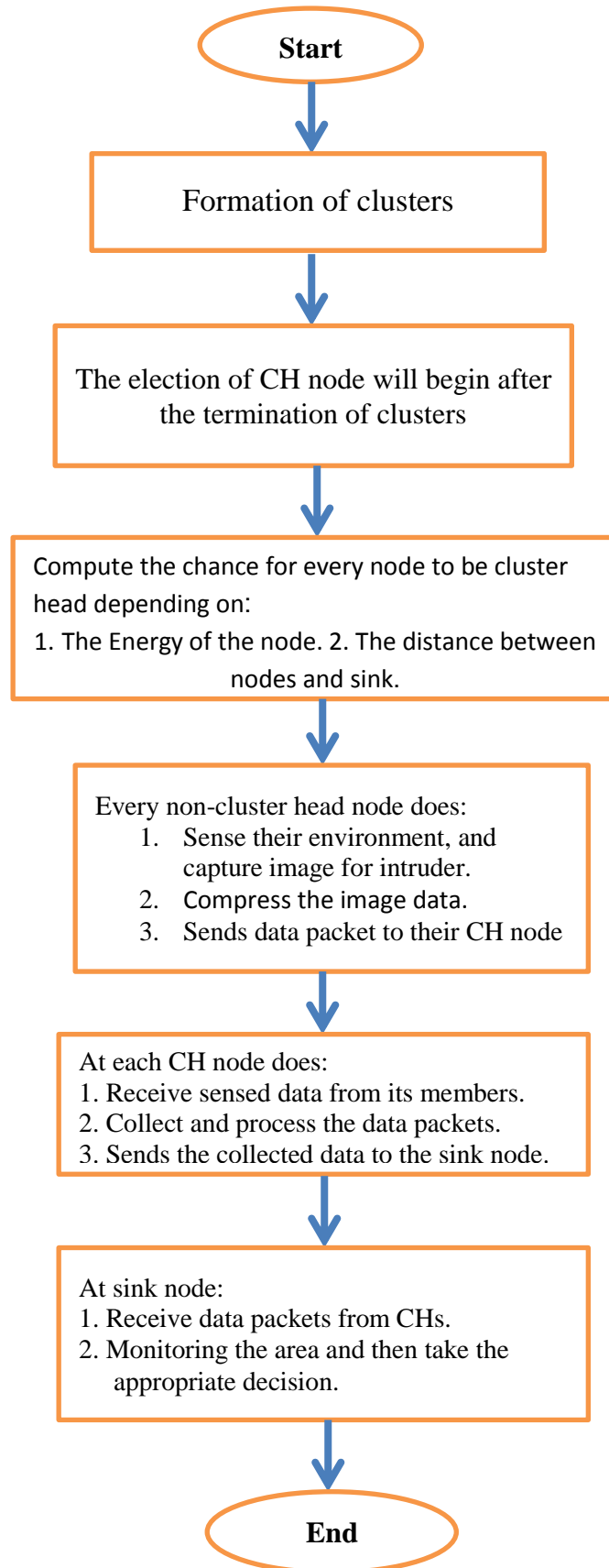

Figure 5: The flow chart of the proposed model

4.1 Energy Model

Generally sensor nodes in WSNs are distributed randomly. The energy is exhausted mainly within communication in WSN as it depends mainly on the distance between each dual node [16]. The energy consumption model can be seen in Figure 6.

The calculation of consumed energy by transceiver unit and the entire consumed energy for intra-clustering communication by radio unit are as follow:

- 1- The sensor member consumed energy through data transmission by its radio electronics.
- 2- The amplifier circuitry of sensors also dissipates a considered energy.
- 3- The cluster head receiver consumed energy through data receiving by its radio electronics.
- 4- Data gathering and processing in cluster head consumed considering energy.
- 5- The transmission and amplification energy by radio electronics of cluster head node to sink.

The processing unit of node member will compress the capture image directly by utilizing an improvement compression technique consists of EZW and SPIHT algorithms which are types of vital compression techniques that used for lossy image compression algorithms. The EZW coding is a worthwhile and simple efficient algorithm. SPIHT is a most powerful technique that used for image compression depends on the concept of coding set of wavelet coefficients as zero trees. This dual combined compression technique. The compressed data will transmit to cluster head which collect data from active nodes and forward it to sink node immediately or by multi-hop.

According to proposed energy model, the total consumed energy in transmission case is compute by collect the consumed energy from camera node and cluster head node. The consumed energy in receiving case is determined by the consumed energy from cluster head to collect data.

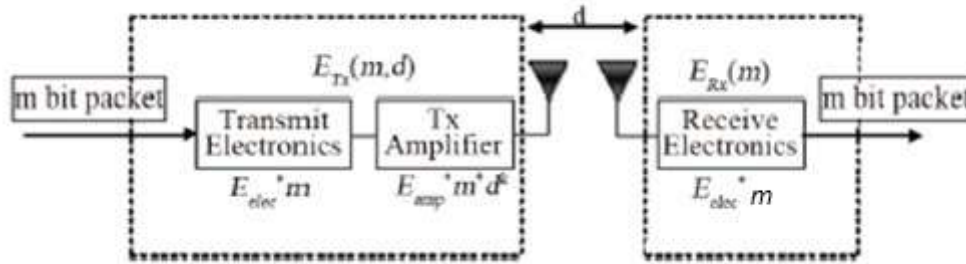

Figure 6: Radio energy dissipation model [16]

4.2 Energy Computation

The radio circuitry of member node will spend energy (E_{elec}) through data transmission, and (E_{amp}) energy for radio amplifier. Therefore, the gross energy for transmission m-bits packet data from member node to cluster head node with distance equal to d is given by:

$$E_{Tx}(m, d) = mE_{elec} + mE_{amp} \times d^2 \dots\dots\dots(1)$$

Where E_{elec} is the consumed energy per bit to run the transceiver circuit, E_{amp} is energy dissipated by amplifier to transmit single bit. d^2 is the distance between ordinary node and commander node, for free space model (less than the crossover distance).

The dissipate energy by cluster head receiver circuitry for receiving m-bit message from associated node is:

$$E_{Rx}(m, d) = E_{elec} \times m \dots\dots\dots(2)$$

The cluster consists of N nodes distributed in area of $M \times M$. Each dissipate energy for cluster head will comes from two ways, by aggregation data from active nodes and by forwarding the collected data to the sink node. Thus, the energy consumed by cluster head is calculated by:

$$E_{ch}(m, d) = N \times E_{Rx}(m, d) + N \times E_{dc} + E_{Rx}(m, d) \dots\dots\dots(3)$$

Where E_{dc} is the data collecting energy. For multi path model the distance from CH to sink node is greater than the radio distance of coverage area in

each cluster. Therefore, the distance for multi path power loss is d^4 . The overall energy dissipated by the CH is given by:

$$E_{ch} = N \times E_{Rx}(m,d) + N \times E_{dc} + mE_{elec} + mE_{tran} \times d^4 \dots\dots\dots(4)$$

Where E_{tran} is the transmitter amplifier energy for multi path model.

4.3 The Proposition of Energy Values

- 1- Initial energy supplied to each node (unit in Joules):

$$E_0=0.5$$

- 2- Energy required to run circuitry (both for transmitter and receiver),

$$E_{elec}=E_{Tx}=E_{Rx} \text{ (in nJoules/bit):}$$

$$E_{elec}=50*10^{(-9)} \text{ (units in nJoules/bit)}$$

$E_{Tx}=50*10^{(-9)}$ is the transmitter energy per node (units in nJoules/bit)

$E_{Rx}=50*10^{(-9)}$ is the receiver energy per node (units in nJoules/bit)

- 3- Energy spent by the amplifier to transmit one bit is:

$$E_{amp}=100*10^{(-12)} \text{ units in (nJoules/bit/m}^2\text{)}$$

The amplification energy in (nJ/bit/m²), when d is less than d_0 (threshold distance) for free space is:

$$E_{fs}=10*0.000000000001$$

The amplification energy in (pJ/bit/m⁴), when d is greater than d_0 in multi path channel is:

$$E_{mp}= 0.0013*0.000000000001$$

Distance between cluster head and base station:

$$d_o= \text{sqrt}(E_{fs}/E_{mp})= 87.7m$$

- 4- Data collecting energy from cluster head node

$$E_{dc}=5*10^{(-9)} \text{ (units in nJoules/bit)}$$

5. Experimental Result

The computation of energy dissipation in intra-clustering communication for transmission of data images before and after utilizing a dual combined compression technique is presented in this paper. Reducing the quantity of transmitting data is considered as a means to improve energy exhausting in order to prolong the entire network lifetime. The

proposed images in this work are elected from a dataset of web JPEG images.

- 1- The elected dataset color images are shown in Figure 7.
- 2- Table 1 presents the image size in byte for dataset images before and after compression.
- 3- Figure 8 shows bar chart of energy dissipation from sensor node before and after utilizing the proposed technique, by using the elected dataset test images.
- 4- Figure 9 shows bar chart of energy dissipation from cluster head node before and after utilizing the proposed technique.
- 5- Figure 10 shows bar chart of gained energy in sensor node and cluster head by utilizing the proposed technique.



a. Guards

b. Border Patrol

c. Air Plane



d. Spinner



e. Battle



f. Patrol

Figure 7: The proposed dataset color images.

Table 1: The image size in byte before and after compression

Image title	File size in byte	File size after 1 st compression	File size after 2 nd compression
Guard	17177	12134	11308
Border Patrol	13977	11783	11131
Air Plane	9935	7231	6737
Sniper	15933	12196	11566
Battle	17329	13935	12461
Patrol	11559	9249	7986

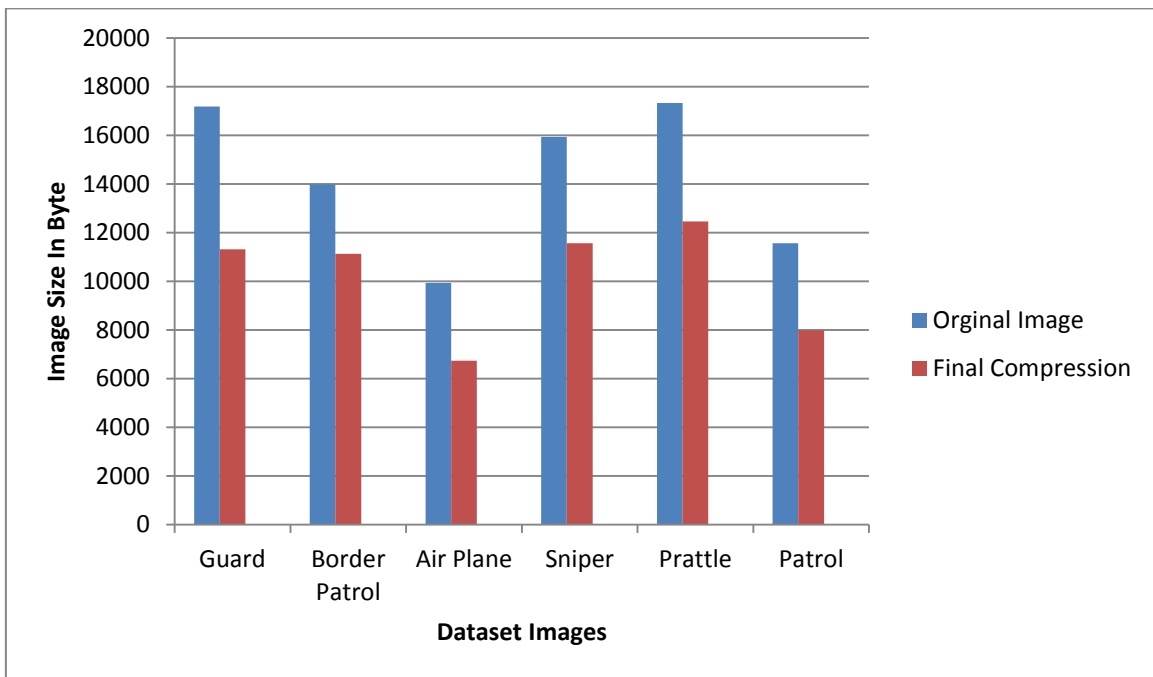

Figure 8: Show bar chart of energy dissipation from sensor node before and after utilizing the proposed technique for the elected dataset test images.

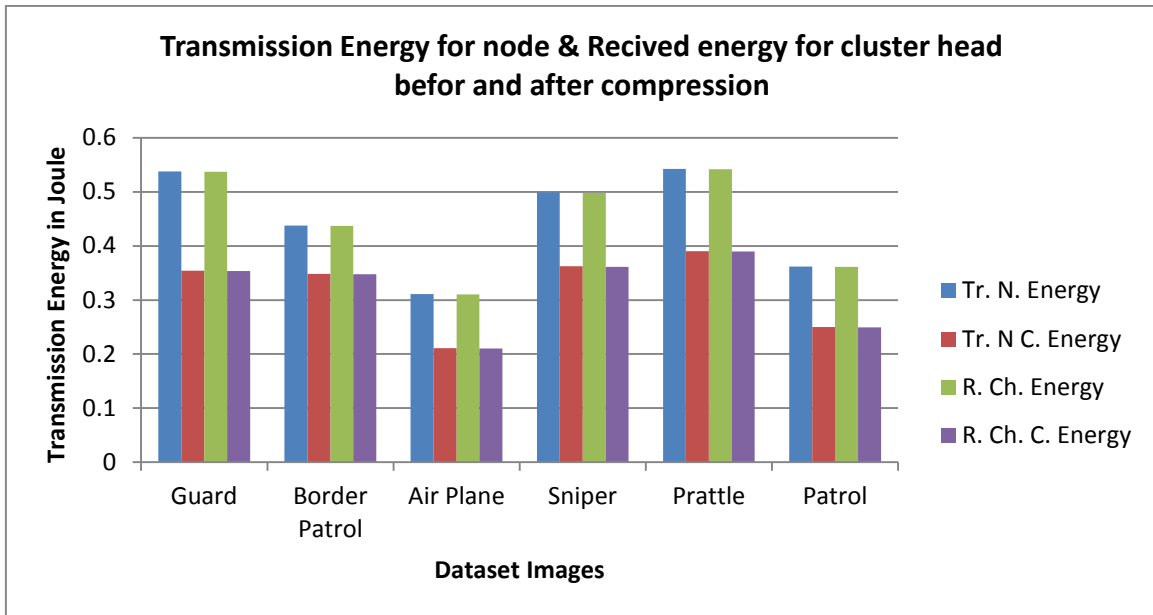

Figure 9: Show bar chart of energy dissipation from active node and cluster head before and after utilizing the proposed technique.

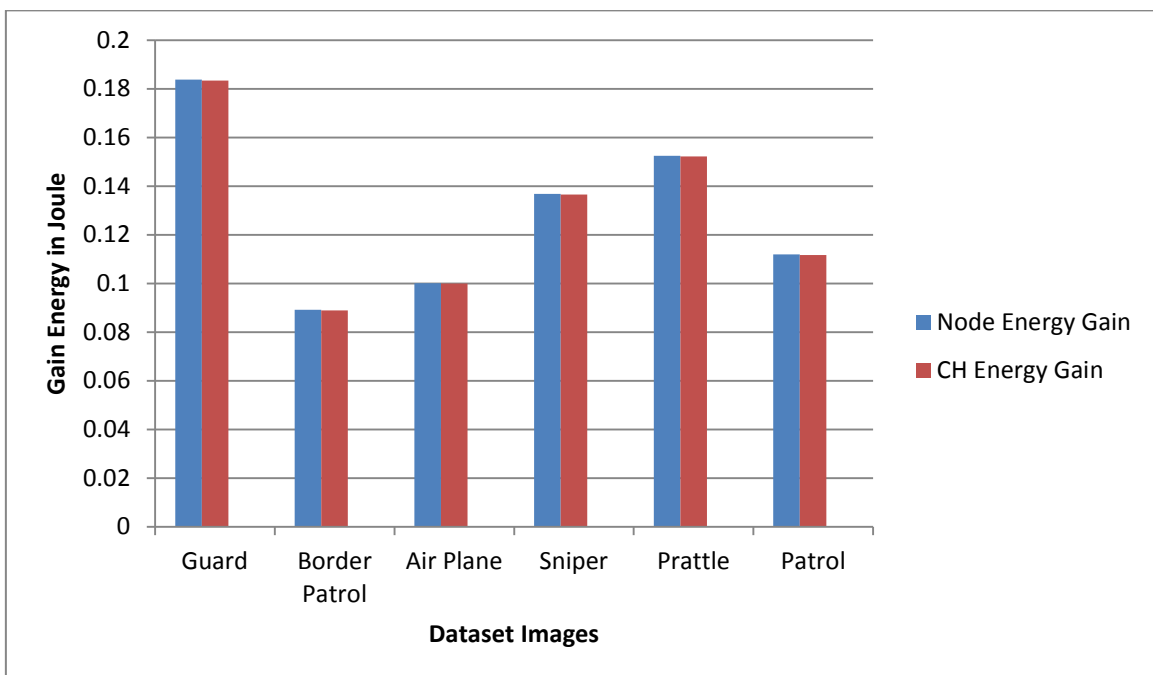

Figure 10: Shows bar chart of gained energy in sensor node and cluster head by utilizing the proposed technique.

6. Conclusion

A dual compression technique for images transmission in limited resources wireless sensor network is being considered. The improvement of promise compression technique for efficient energy dissipation is present

and examine. In order to overcome the limitation of energy resources for individual nodes in intra-clustering communication, the consumed energy and image quality must be considered. The proposed technique has extra advantage in improving the decreasing of energy dissipation to prolong the entire network lifetime, by present a significant data reduction for the elected dataset images.

There have been several attempts by researchers who preceded us in this field and their results were promising, but using this method of image compression has reduced the volume of data transferred and will improved the amount of dissipated energy from the wireless sensors. The practical results shows that the proposed image compression combining techniques will enhance the efficiency of compression ratio between 8.1 to 31.4%, and will present a promising preservation energy technique in intra-clustering communication by the ratio between 17.8 to 36.7% (depends on the specifications of the tested image), which prolong the network lifetime.

From the results obtained, it became clear to us that the image with high color variation has high compression ratio, lead to get high gain in energy to compress the elected image and to transmit the image data by active node. In the future, image compression methods can be used that do not significantly affect the quality of the transmitted data images.

7. References

- [1] SCHS: Smart Cluster Head Selection Scheme for Clustering Algorithms in Wireless Sensor Networks;
Vipin Pall, Girdhari Singh², Rajender Prasad Yadav³, 2012
- [2] Xiaoliang Meng , Xiaochuan Shi , Zi Wang , Shuang Wu , Chenglin Li; "A Grid-Based Reliable Routing Protocol for Wireless Sensor Networks with Randomly Distributed Clusters"; 2016.
- [3] E. Thenmozhi and S. Audithan; "Energy Efficinet Cluster Head Selection and Data Convening in Wireless Sensor Networks"; Indian Journal of Science and Technology, Vol 9(15) April 2016
- [4] Vlab. Amrita education; Clustering Algorithm; Retrieved 24 April 2019, from <http://vlab.amrita.edu/?sub=78&brch=256&sim=1558&cnt=1>
- [5] S.Saidarao, R.A.R Chandra Sekhar; "Proactive and Reactive Routing Protocols In Wireless Sensor Networks"; 2017.
- [6] A. A. Abbasi and M. Younis, "A.S Algorithms for Wireless Sensor Networks," Computer Communication, Vol. 30, No. 14-15, 2007, pp. 2826-2841.
- [7] D. C. Chinh, R. Kumar and S. K panda; "Optimal data aggregation Tree in Wireless Sensor Networks Based on intelligent water drops

- algorithms". IET wireless sensor system, Vol. 2, No. 3, 2012, pp 282-292. [doi:10.1049/iet-wss.2011.0146](https://doi.org/10.1049/iet-wss.2011.0146)
- [8] C. B. Mudgule et. al.; "Data Compression in Wireless Sensor Network: A Survey"; IJIRCCE- 2014
- [9] Mohsen Nasri et al.; "Images compression techniques for wireless sensor network applications"; Int J Speech Technol (2015) 18:205–216 DOI 10.1007/s10772-014-9261-5
- [10] Y. LI and Y. LIANG; "Temporal Lossless and Lossy Compression in Wireless Sensor Networks"; Indiana University – Purdue University Indianapolis; ACM Trans. Sen. Netw. 12, 4, Article 37 (October 2016), 35 pages.
- [11] Amr M. Kishk et. al.; "Hybrid Compression Algorithm for Wireless Sensor Network"; Journal of Advances in Computer Networks, Vol. 2, No. 2, June 2014
- [12] Mohsen Nasri et. al.;" Image compression technique with low power consumption for wireless sensor networks"; International Conference on Control, Engineering & Information Technology; Proceedings Engineering & Technology - Vol.2, pp. 15-20, 2013.
- [13] C. B. Mudgule et. al.;" Data Compression in Wireless Sensor Network: A Survey"; IJIRCCE- 2014.
- [14] Ciancio A, Ortega A.,"A distributed wavelet compression algorithm for WSNs using lifting", IEEE International Conference on Acoustics, Speech and Signal processing (ICASSP),vol. 4,p.iv 633-6,2014.
- [15] Shikang Kong et. al.; "An Image Compression Scheme in Wireless Multimedia Sensor Networks Based on NMF"; 24 February 2017.
- [16] Simimol. Surendran and Ajitsinh Jadhav; 'IMPLEMENTATION OF SMART CLUSTER HEAD SELECTION SCHEME ON LEACH PROTOCOL'; January 2012 *with 22 Reads*.
- [17] Y. Qi, J. Yu, N. Wang, An energy-efficient distributed clustering algorithm for wireless sensor networks, Computer Engineering 37 (1) (2011) 83-86.
- [18] M. Stemm, R.H. Katz, Measuring and reducing energy consumption of network interfaces in hand-held devices, IEICE Transactions on Communications E80-B (8) (2007) 1125–1131.
- [19] J. Yu, Y. Qi, G. Wang, X. Gu, A cluster-based routing protocol for wireless sensor networks with Non uniform node distribution, AEU-International Journal of Electronics and Communications 66 (2002) 54-61.
- [20] Mohsen Nasri et. al.; "Adaptive image transfer for wireless sensor networks (WSNs)"; 2010 International Conference on Design & Technology of Integrated Systems in Nanoscale Era.